

CUSTOMER SIGNATURE: _____

DATE: _____

IN AN EFFORT TO ENSURE ACCURACY, PLEASE REVIEW YOUR DRAWING DIMENSIONS AND FITTING SIZES FOR POSSIBLE ERRORS AND OMISSIONS. CALL WITH ANY CORRECTIONS BEFORE SIGNING THIS DRAWING. ALL TANKS DESIGNED AND/OR BUILT, IN PART OR COMPLETE, BY ALUMITANK OR ANY OF ITS PEOPLE ARE CERTIFIED FOR USE ONLY WITH DISTILLATE, HYDRAULIC, OR WATER. ANY VARIATIONS OF USE OR MODIFICATIONS OF THE TANK ARE PROHIBITED. CUSTOMER SIGNATURE ON DOCUMENT/DRAWING INDICATES AGREEMENT BY SIGNER OR RECIPIENT OF TANK AND HOLDS ALUMITANK HARMLESS.

CUSTOMER NAME:

SIDE OF TRUCK:

SHOP #:

PARTS:

FINISH:

CAPACITY:

SERIAL #:

CHASSIS STYLE:

SHIP DATE:

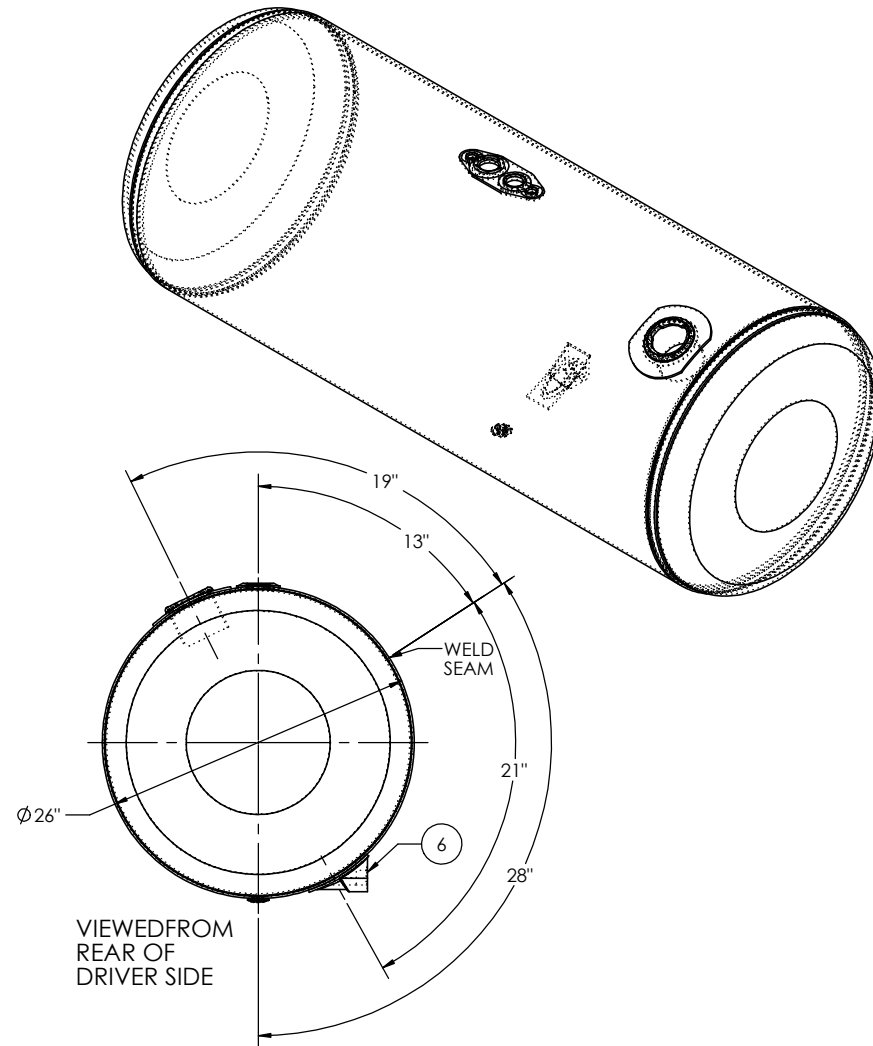
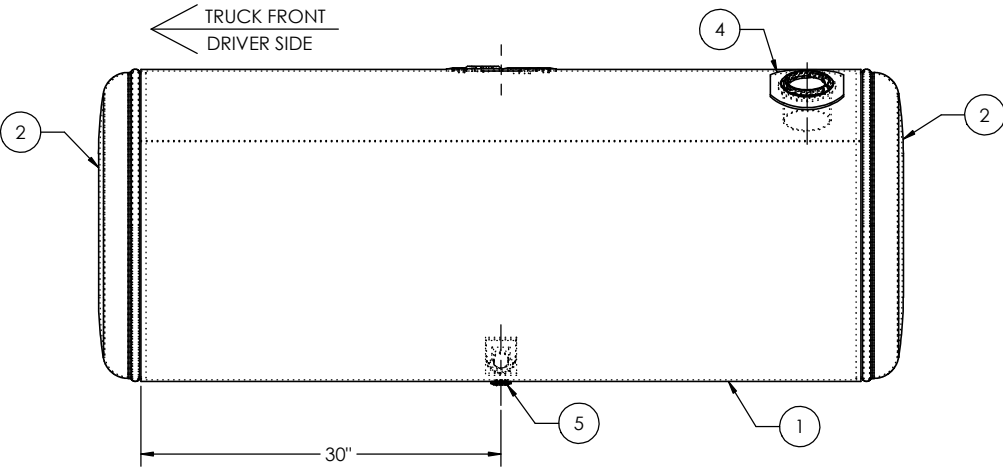
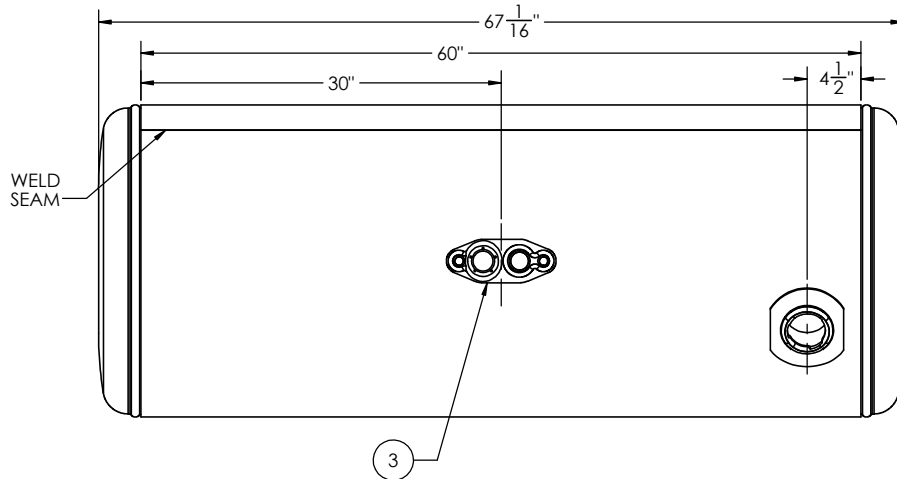

| ITEM NO. | PART NUMBER | DESCRIPTION | AT-PB-1005/QTY. |
|----------|-------------------|---|-----------------|
| 1 | BRL-AT-PB-60-ADPT | 1/8" TANK BARREL | 1 |
| 2 | ECP-4160013200 | 26" POLISHED ALUMINUM PETERBILT STYLE END CAP | 2 |
| 3 | ADP-1132310 | POLISHED ALUMINUM PETERBILT ADAPTER PLATE | 1 |
| 4 | FLN-110022300 | POLISHED ALUMINUM PETERBILT FILL NECK | 1 |
| 5 | FLG-050230 | 1/2" NPTF POLISHED ALUMINUM FLANGE | 1 |
| 6 | COC-70210 | 1" NPTF CAST ALUMINUM CASTING | 1 |

| | | | | | |
|------------------|-----|-----------------------------|----------|---|------|
| TITLE: | | UNLESS OTHERWISE SPECIFIED: | | NAME | DATE |
| SIZE C | REV | QC | INITIALS | DRAWN | |
| | | PSI | | CHECKED | |
| | | DIMS | | ENG APPR. | |
| | | PARTS | | MFG APPR. | |
| TAG | | Q.A. | | COMMENTS: | |
| PKG | | MATERIAL: 5052 H32 ALUMINUM | | 11317 N. US HWY 14 HARVARD, IL 60033 800-652-6630 FAX 855-774-6918 WWW.ALUMITANK.COM INFO@ALUMITANK.COM | |
| | | FINISH: SEE BOM | | DWG. NO. AT-PB-1005 | |
| | | DO NOT SCALE DRAWING | | SCALE: 1:10 WEIGHT: SHEET 1 OF 1 | |

