

CUSTOMER SIGNATURE: _____

DATE: _____

IN AN EFFORT TO ENSURE ACCURACY, PLEASE REVIEW YOUR DRAWING DIMENSIONS AND FITTING SIZES FOR POSSIBLE ERRORS AND OMISSIONS. CALL WITH ANY CORRECTIONS BEFORE SIGNING THIS DRAWING. ALL TANKS DESIGNED AND/OR BUILT, IN PART OR COMPLETE, BY ALUMITANK OR ANY OF ITS PEOPLE ARE CERTIFIED FOR USE ONLY WITH DISTILLATE, HYDRAULIC, OR WATER. ANY VARIATIONS OF USE OR MODIFICATIONS OF THE TANK ARE PROHIBITED. CUSTOMER SIGNATURE ON DOCUMENT/DRAWING INDICATES AGREEMENT BY SIGNER OR RECIPIENT OF TANK AND HOLDS ALUMITANK HARMLESS.

CUSTOMER NAME:

SIDE OF TRUCK:

SHOP #:

PARTS:

FINISH:

CAPACITY:

SERIAL #:

CHASSIS STYLE:

SHIP DATE:

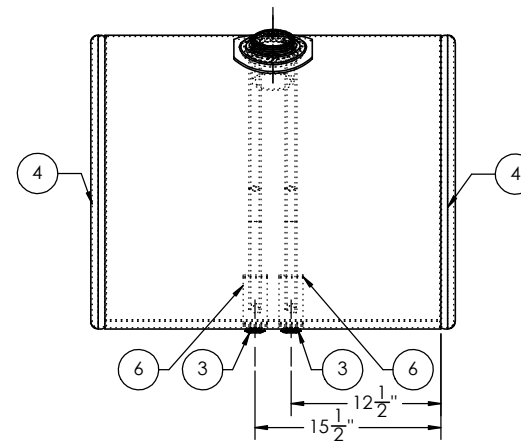
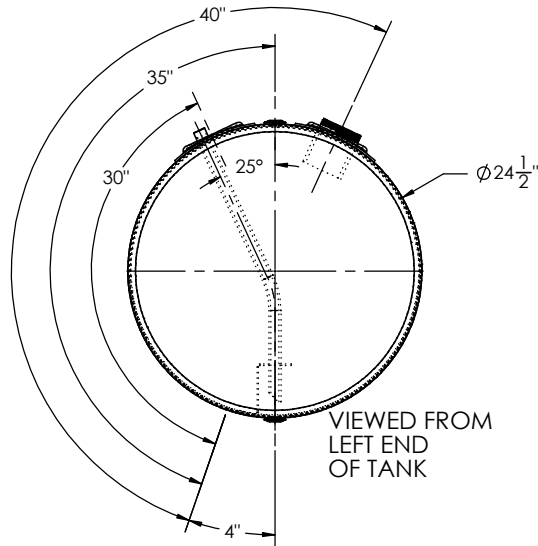
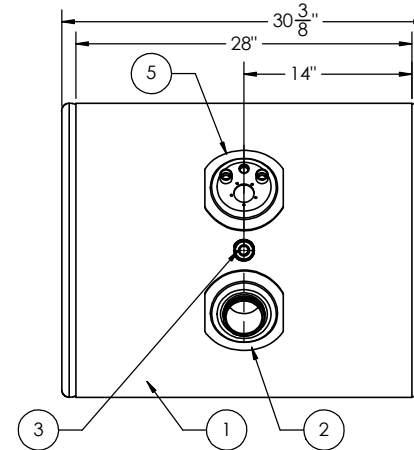
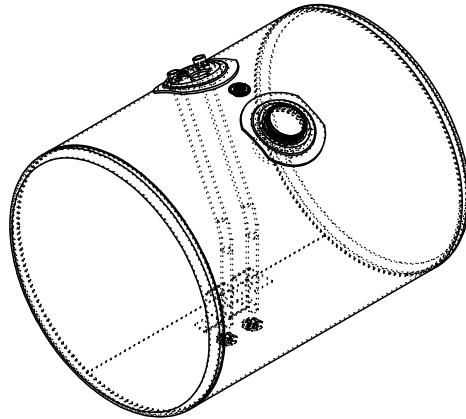

ITEM NO.	PART NUMBER	DESCRIPTION	QTY.
1	BRL-K444-0356N0356U060	1/8" TANK BARREL	1
2	FLN-801212200	MILGRADE ALUMINUM KENWORTH FILL NECK	1
3	FLG-050220	1/2" NPTF MILGRADE ALUMINUM FLANGE	3
4	ECP-3920012100	24 1/2 MILGRADE ALUMINUM END CAP	2
5	ADP-83222392	24 1/2 MILGRADE ALUMINUM KENWORTH ADAPTER PLATE WITH TUBES	1
6	STR-001	STABILIZER FOR TUBE	2

TITLE:		UNLESS OTHERWISE SPECIFIED:		NAME	DATE
SIZE C	REV	QC	INITIALS	DRAWN	
		PSI		CHECKED	
		DIMS		ENG APPR.	
		PARTS		MFG APPR.	
TAG		MATERIAL: 5052 H32 ALUMINUM		DIA:	
PKG		FINISH: SEE BOM		COMMENTS:	
		DO NOT SCALE DRAWING			

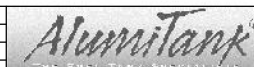

11317 N. US HWY 14 HARVARD, IL 60033 815-943-6649

800-652-6630 FAX 855-774-6918 WWW.ALUMITANK.COM INFO@ALUMITANK.COM

DWG. NO. K444-0356N0356U060

SCALE: 1:8 WEIGHT: SHEET 1 OF 1